

Q110S TV1

LED
QUAD STEEL

= WITH DOUBLE ROW LIGHT PATTERN

Underwater spotlight

High performance in unique design: the housing is made of solid stainless steel. The magnetic mounting is a pleasant feature. The selective frosting of the clear glass lens provides a low-glare spotlight. The absence of optical systems significantly increases efficiency. Latest LED technology in RGBW provides seamless color changes and a clear white. Sophisticated design, durable, efficient, simply WEAD.

The recessed niche is optionally available for:

- Stainless steel
- PVC liner
- Concrete



Specifications

- Installation opening: 116x116 mm
- Installation depth: 60 mm
- Housing: V4A stainless steel
- Cover: V4A stainless steel
- Power LED ON 75Watt
- No visible screws
- Magnetic fixing in 1.4462 pot
- With dedicated white in 4500K (daylight)
- Selective matting
- Illumination angle approx. 160°

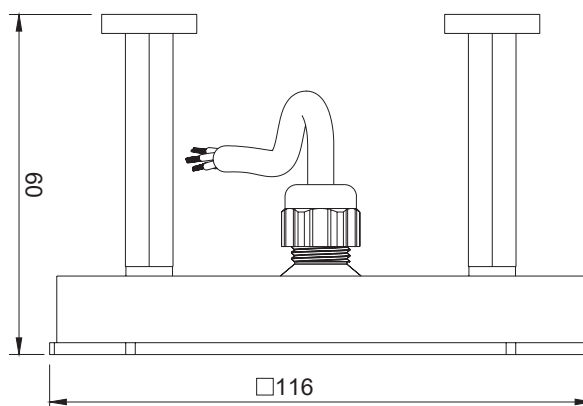

Standard

- System voltage 30 VDC
- Constant current 700mA
- RGBW: color change with dedicated white
- 15m connection cable

Customized

- Custom branding
- Cable length
- Reduced installation depth

Accessories

- Stainless steel niche
- PVC niche
- Concrete niche
- DMX Ctrl or CC Box

